

Serie

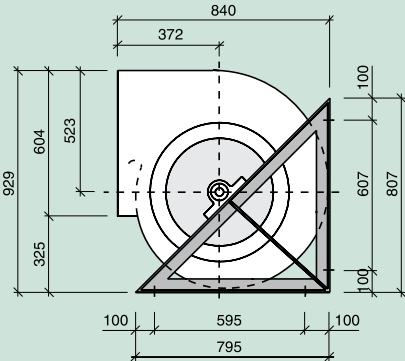

SR

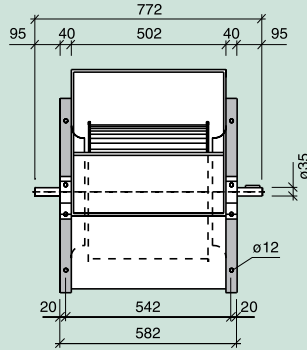

Solamente en orientaciones

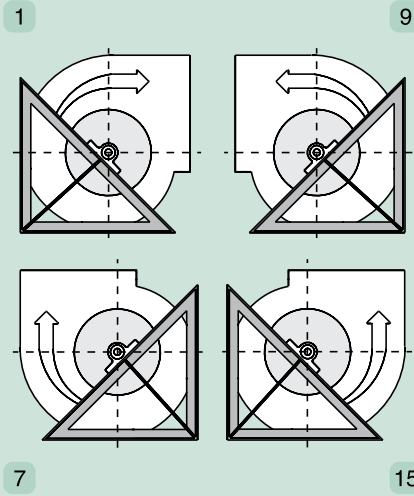

Serie

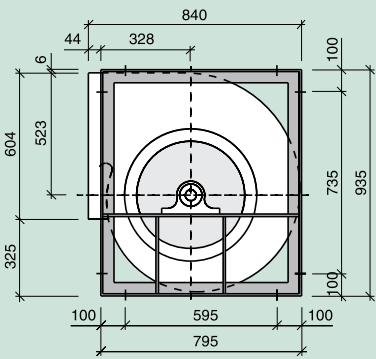

R

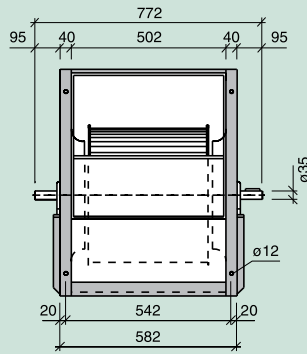

Serie

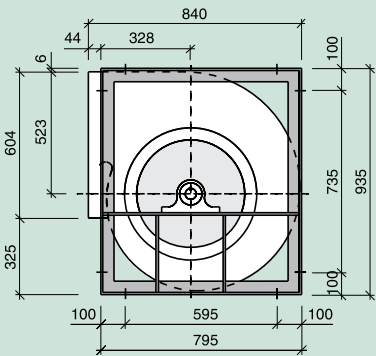

T2R

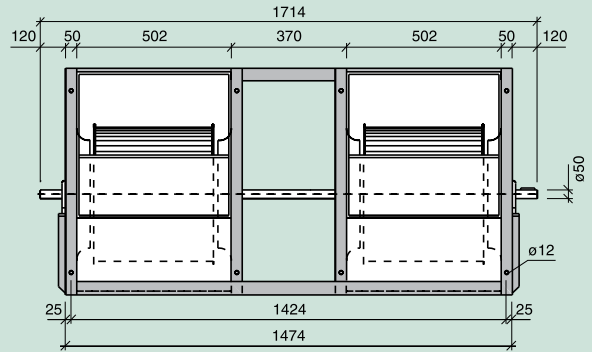

Serie - Series - Serie			SR	R		T2R	T3R
Límite de empleo. Operational limit. Limite d'emploi.	n max. motor max.	rpm kW	900 7.5	900 7.5		950 17	900 20
Velocidad tangencial. Tip speed. Vitesse tangentielle.	u	m/s	n (min ⁻¹) x 0.0288				
Momento de inercia. Moment of inertia. Moment d'inertie.	PD ² /4	Kg m ²	0.99	0.99		1.98	2.97
Peso del ventilador. Fan weight. Poids du ventilateur.		Kg	63	72		170	275
Coefficientes de corrección. Correction factors. Coefficients de correction.	V P _A n	m ³ /h kW min ⁻¹	x 1 x 1 x 1	x 1 x 1 x 1		x 2 x 2.15 x 1.05	x 3 x 3.25 x 1.08

