

**Serie**

**SR**

Solamente en orientaciones

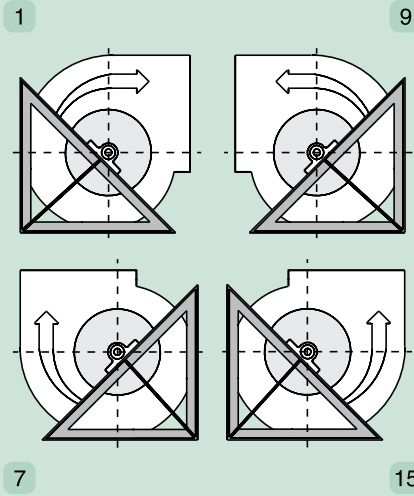
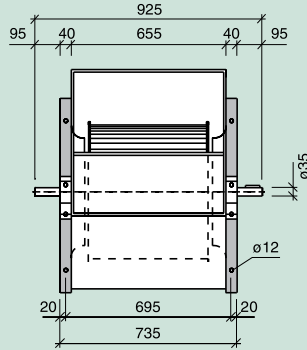
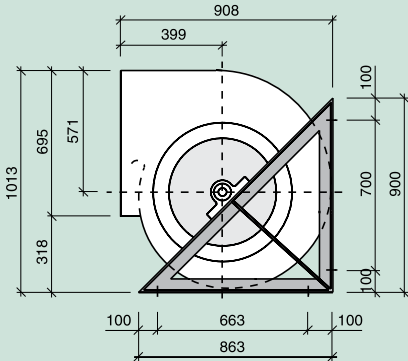

**Serie**

**R**

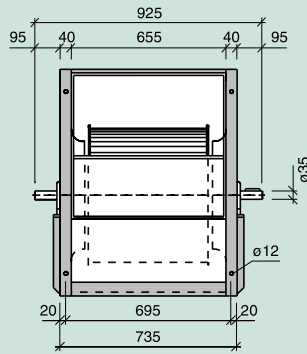
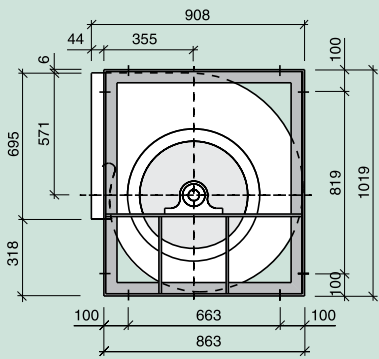

**Serie**

**T2R**

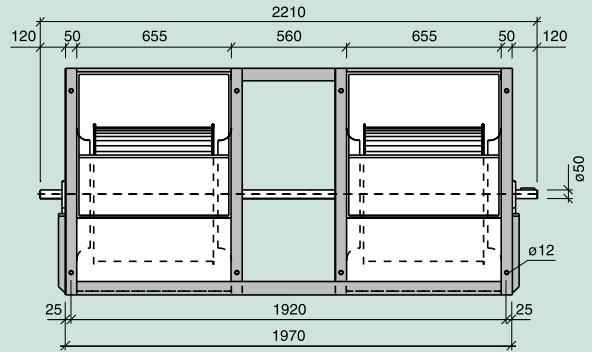
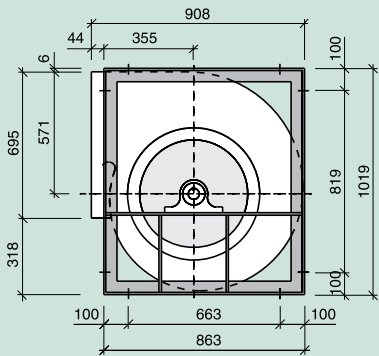

Serie - Series - Serie			SR	R			T2R	T3R
<b>Límite de empleo.</b> <i>Operational limit.</i> <i>Limite d'emploi.</i>	n max. motor max.	rpm kW	700 8	900 11.5			850 20	800 23
<b>Velocidad tangencial.</b> <i>Tip speed.</i> <i>Vitesse tangentielle.</i>	u	m/s	n (min <sup>-1</sup> ) x 0.0314					
<b>Momento de inercia.</b> <i>Moment of inertia.</i> <i>Moment d'inertie.</i>	PD <sup>2</sup> /4	Kg m <sup>2</sup>	1.60	1.60			3.19	4.79
<b>Peso del ventilador.</b> <i>Fan weight.</i> <i>Poids du ventilateur.</i>		Kg	83	94			215	345
<b>Coefficientes de corrección.</b> <i>Correction factors.</i> <i>Coefficients de correction.</i>	V P <sub>A</sub> n	m <sup>3</sup> /h kW min <sup>-1</sup>	x 1 x 1 x 1	x 1 x 1 x 1			x 2 x 2.15 x 1.05	x 3 x 3.25 x 1.08

