

**Serie**

**SR**

Solamente en orientaciones

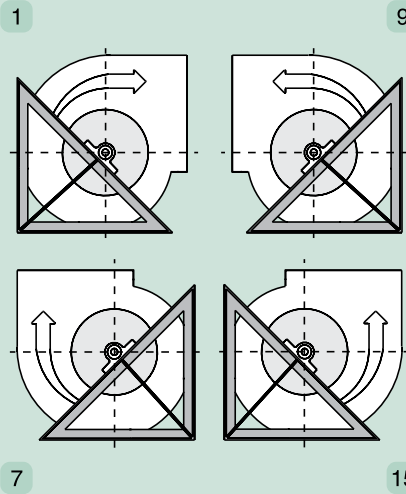
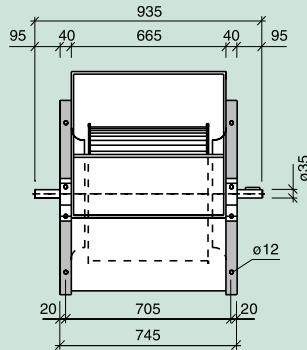
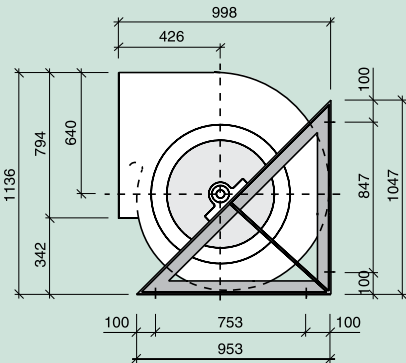

**Serie**

**R**

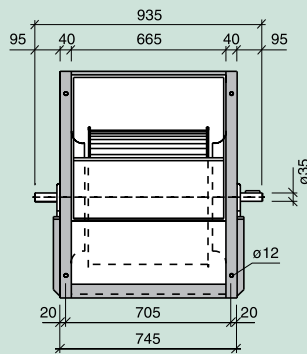
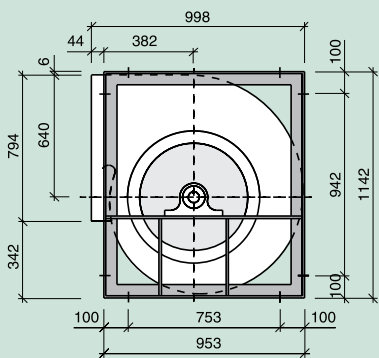

**Serie**

**T2R**

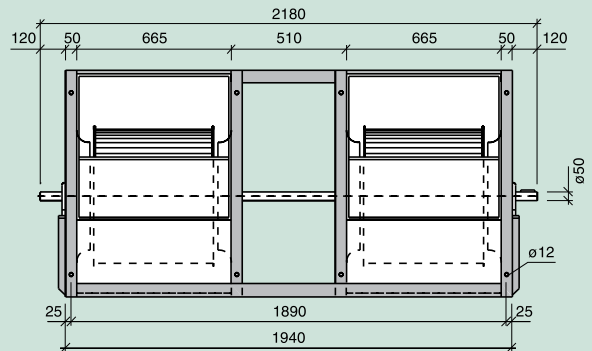
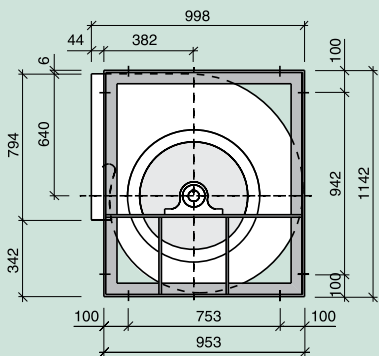

Serie - Series - Serie			SR	R		T2R	T3R
<b>Límite de empleo.</b> <i>Operational limit.</i> Limite d'emploi.	n max. motor max.	rpm kW	550 9	700 11		650 23	600 26
<b>Velocidad tangencial.</b> <i>Tip speed.</i> Vitesse tangentielle.	u	m/s	n (min <sup>-1</sup> ) x 0.0351				
<b>Momento de inercia.</b> <i>Moment of inertia.</i> Moment d'inertie.	PD <sup>2</sup> /4	Kg m <sup>2</sup>	2.28	2.28		4.56	6.84
<b>Peso del ventilador.</b> <i>Fan weight.</i> Poids du ventilateur.		Kg	88	100		235	384
<b>Coefficientes de corrección.</b> <i>Correction factors.</i> Coefficients de correction.	V P <sub>A</sub> n	m <sup>3</sup> /h kW min <sup>-1</sup>	x 1 x 1 x 1	x 1 x 1 x 1		x 2 x 2.15 x 1.05	x 3 x 3.25 x 1.08

