

Serie

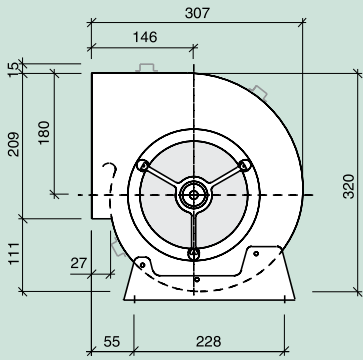

L

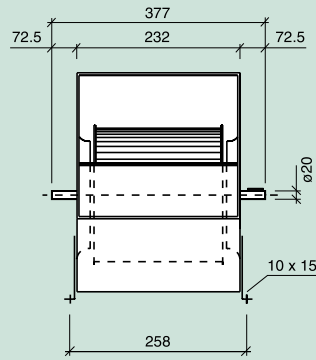

T2L

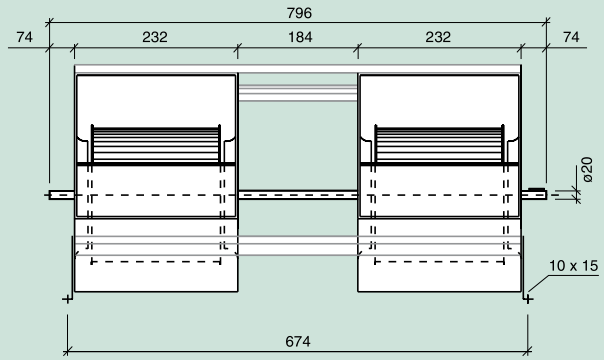

Serie

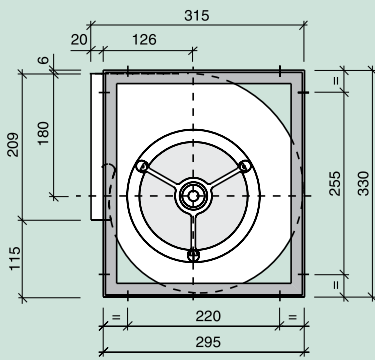

SR

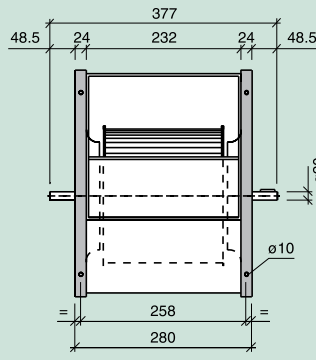

T2SR

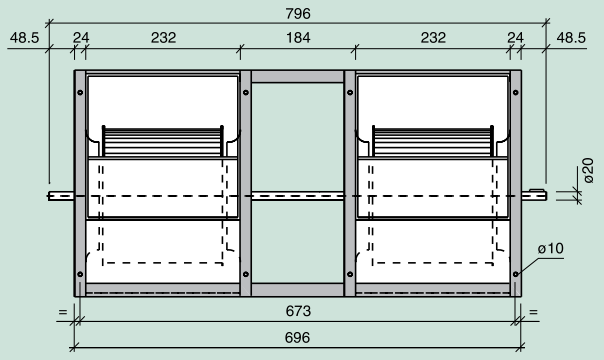

Serie

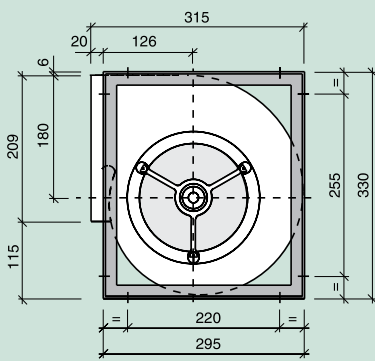

R

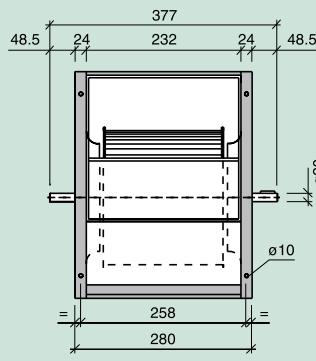

Serie - Series - Serie		L	SR	R	T2L	T2SR	T2R	T3R
Límite de empleo. Operational limit. Limite d'emploi.	n max. motor max.	rpm kW	2500 1	2700 1.2	3100 1.5	2400 1.5	2500 1.5	
Velocidad tangencial. Tip speed. Vitesse tangentielle.	u	m/s	n (min ⁻¹) x 0.0097					
Momento de inercia. Moment of inertia. Moment d'inertie.	PD ² /4	Kg m ²	0.02	0.02	0.02	0.04	0.04	
Peso del ventilador. Fan weight. Poids du ventilateur.		Kg	5	6	7	11.5	13	
Coefficientes de corrección. Correction factors. Coefficients de correction.	V P _A n	m ³ /h kW min ⁻¹	x 1 x 1 x 1	x 1 x 1 x 1	x 1 x 1 x 1	x 2 x 2.15 x 1.05	x 2 x 2.15 x 1.05	

