

Serie

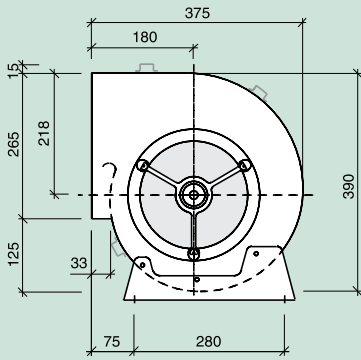

L

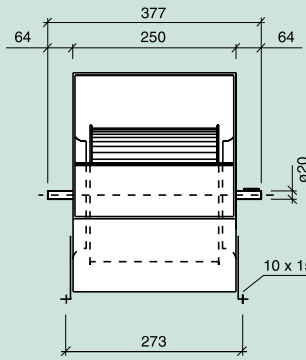

T2L

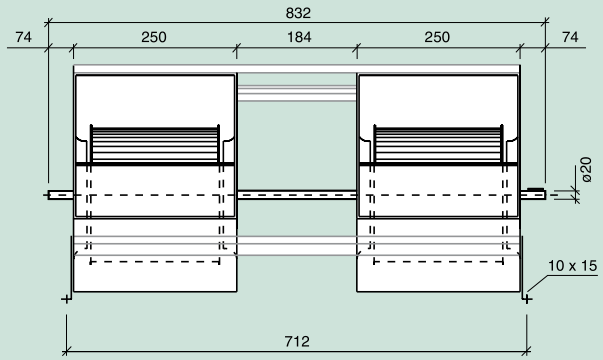

Serie

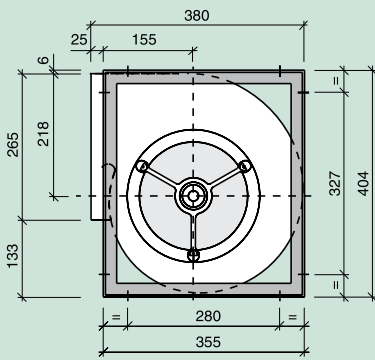

SR

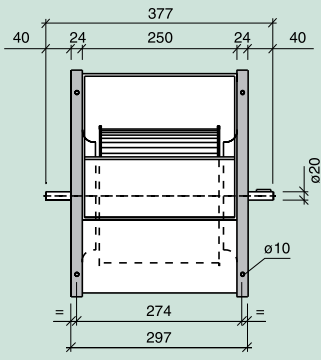

T2SR

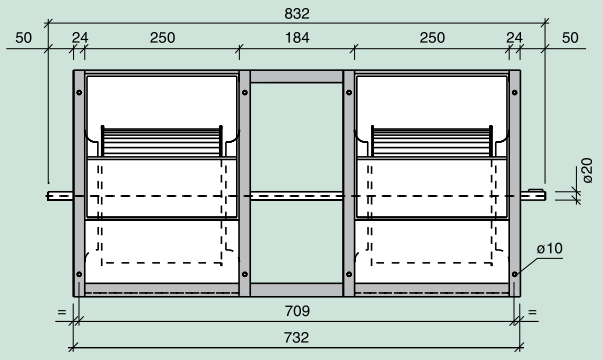

Serie

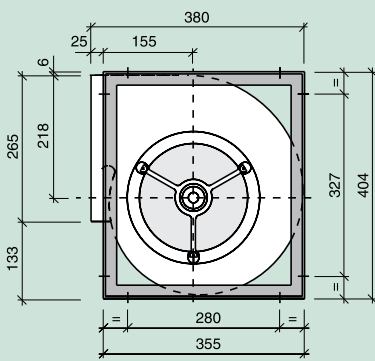

R

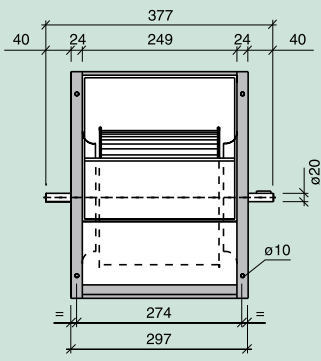

Serie

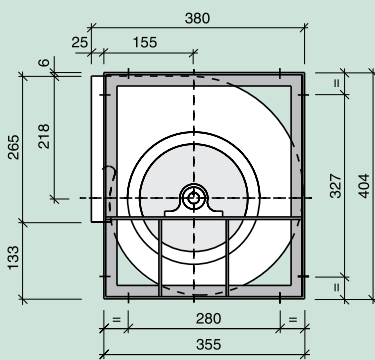

T2R

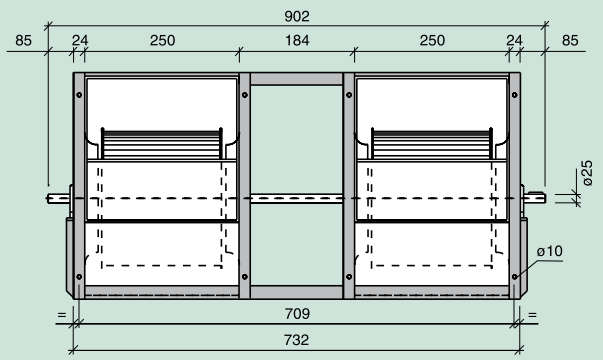

Serie - Series - Serie			L	SR	R	T2L	T2SR	T2R	T3R
Límite de empleo. Operational limit. Limite d'emploi.	n max. motor max.	rpm kW	2000 1.5	2100 1.5	2400 2	1800 1.5	2100 2	2400 3	1800 4.5
Velocidad tangencial. Tip speed. Vitesse tangentielle.	u	m/s	n (min ⁻¹) x 0.0126						
Momento de inercia. Moment of inertia. Moment d'inertie.	PD ² /4	Kg m ²	0.03	0.03	0.03	0.06	0.06	0.06	0.09
Peso del ventilador. Fan weight. Poids du ventilateur.		Kg	8.5	10.5	11	19	20	25	40
Coefficientes de corrección. Correction factors. Coefficients de correction.	V P _A n	m ³ /h kW min ⁻¹	x 1 x 1 x 1	x 1 x 1 x 1	x 1 x 1 x 1	x 2 x 2.15 x 1.05	x 2 x 2.15 x 1.05	x 2 x 2.15 x 1.05	x 3 x 3.25 x 1.08

